



# WANLE·RIDES



ZHENGZHOU WANLE AMUSEMENT EQUIPMENT CO., LTD  
Web: [www.wanlerides.com](http://www.wanlerides.com); Tel: +86 17538705800; Mail: [sales@wanlerides.com](mailto:sales@wanlerides.com)  
Address: No31, South Jinjiang Road, Shangjie District (Amusement Equipment Zone),  
Zhengzhou City, Henan Province, China.



## Zhengzhou Wanle Amusement Equipment Co., Ltd



Wanle amusement equipment company, founded in 1996, located in Zhengzhou, China. Started from carousel manufacturing, now specially in manufacturing small and medium-sized amusement equipment. More concentrated on the products quality and after-sale service. "Wanle" enjoys a high reputation in the industry and the domestic market, and at the same time has created an international brand effect.



Our factory is 25,000 square meters, with FRP production workshop, machine workshop, painting room, parts production workshop, storage room, and show room in 6 parts. More than 10 people in design, more than 90 manufacturing workers. Being a source of development, we are very focused on lean manufacturing, high-level configuration, striking appearance, professional mechanical principle, making products with stable, reliable operation and beautiful appearance. We always trust that good service and quality is the key for a long-term and trustful cooperation with our customers.



"Quality first, stability, safety and reliability" is our company's strategic concept. With the mission of "becoming first-class in the industry and going abroad to the world". We insist on the corporate culture of "creating value for customers", gathering resources and strengths from shareholders, employees, suppliers, customers, etc., building an efficient management service team, and achieving "A century-old enterprise" dream.



[www.wanleyouyi.cn](http://www.wanleyouyi.cn)



### Specifications

Capacity: 28 persons  
 Power: 12.5 kW  
 Voltage: 380V/50kW  
 Machine diameter: 8.9m  
 Area diameter: 7.6m  
 Speed: 1.9m/s

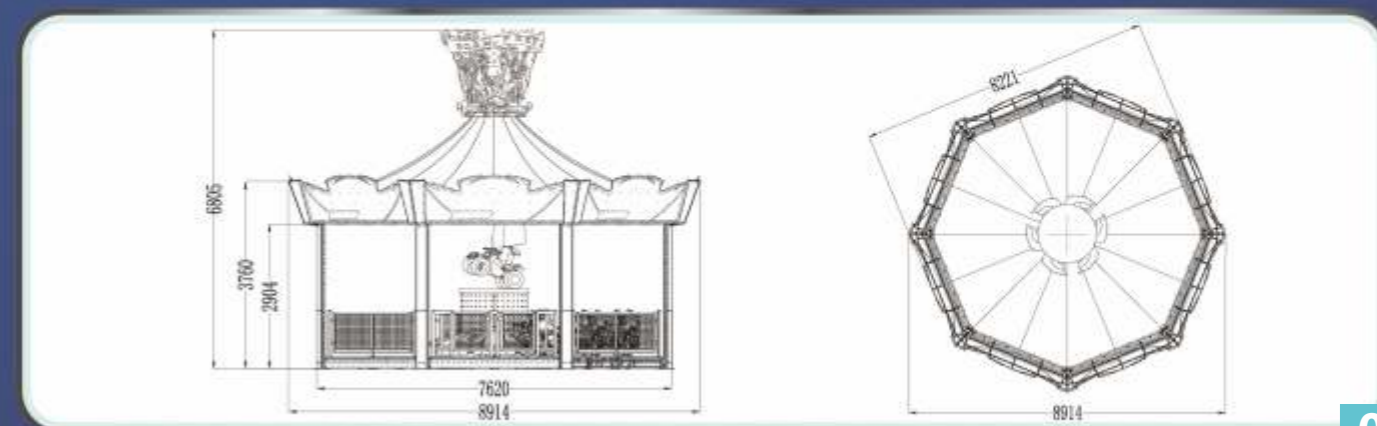



## Specifications

Capacity: 36 persons  
 Cabins: 6x3 pcs  
 Power: 16kW  
 Voltage: 380V/50kW  
 Machine diameter: 13m  
 Area diameter: 15.5m  
 Height: 6.5m  
 weight: 16.5t

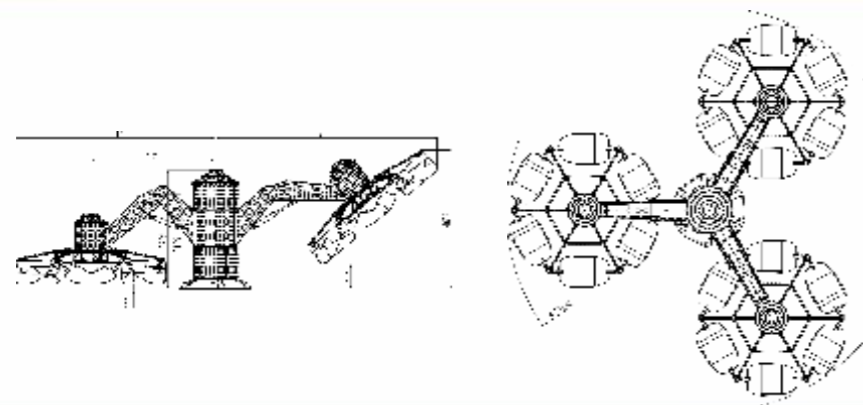



专利产品 仿冒必究  
 专利号: 201710214052.1



Specifications

Capacity: 24persons  
 Cabins: 12pcs  
 Power: 18.5kW  
 Voltage: 380V/50Hz  
 Machine diameter: 13m  
 Area diameter: 15m  
 Height: 5.3m  
 Speed: 1.98m/s

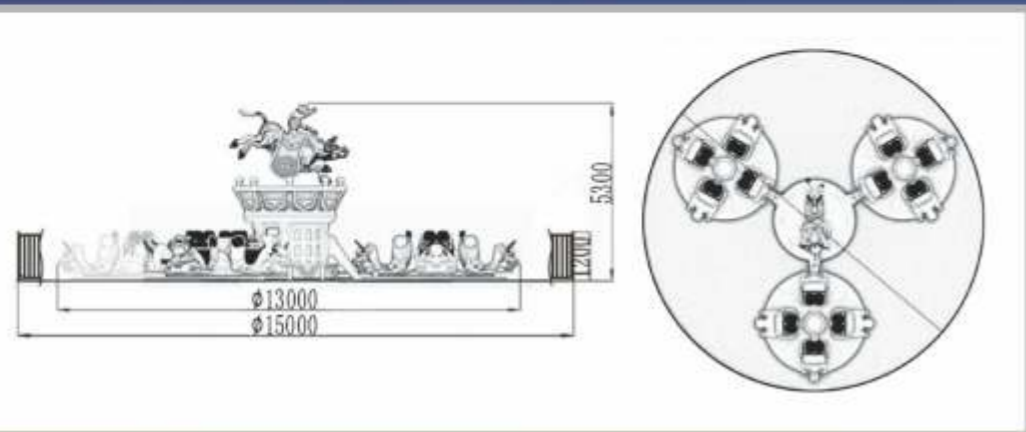



专利产品 仿冒必究  
专利号: 201510117056

### Specifications

Capacity: 30persons  
Cabins: 15pcs  
Power: 19.5kW  
Voltage: 380V/50Hz  
Machine diameter: 12.6m  
Area diameter: 13m  
Height: 5.3m  
Speed: 1.88rpm

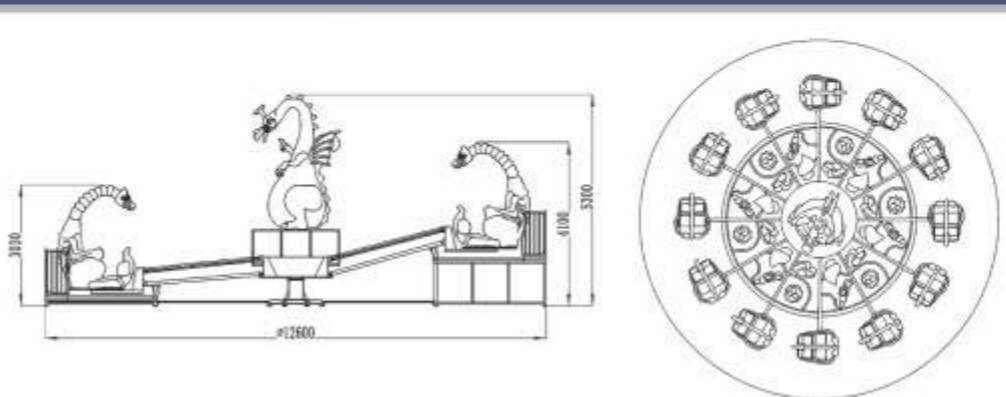



Specifications

Capacity: 12persons  
 Cabins: 6 set  
 Power: 3.5kW  
 Voltage: 380V/50Hz  
 Track length: 50m  
 Area size: Be customized  
 Minimum turning radius: 2.8m  
 Speed: 1.9m/s

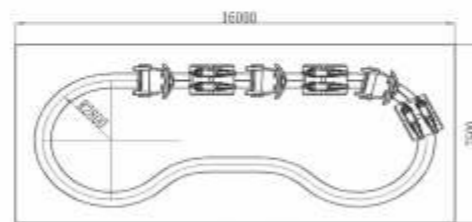
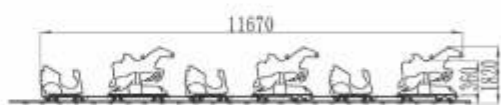



Specifications

Capacity: 72persons  
Cabins: 18pcs  
Total height: 30m  
Power: 20kW  
Voltage: 380V/50Hz  
Wheel diameter: 25.6m  
Area size: 16\*19m

Specifications

Capacity: 104persons  
Cabins: 28pcs  
Total height: 46m  
Power: 25KW  
Voltage: 380V/50Hz  
Wheel diameter: 41m  
Area size: 29\*24m





**Specifications**

Capacity: 30 persons  
 Area: 24m×18m  
 Static Height: 14.5m  
 Moving Height: 20,5m  
 Swing angle: ±110°  
 Power: 150kW



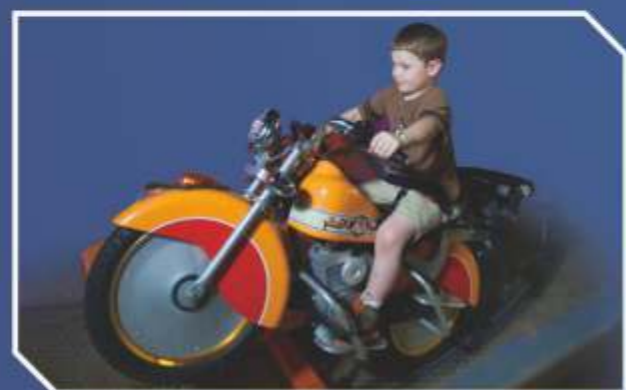

专利产品 仿冒必究  
专利号: A12050353

**Specifications**  
Capacity: 28persons  
Power: 13.5kW  
Voltage: 380V/50Hz  
Machine diameter: 11m  
Area diameter: 12m  
Speed: 1.98m/s

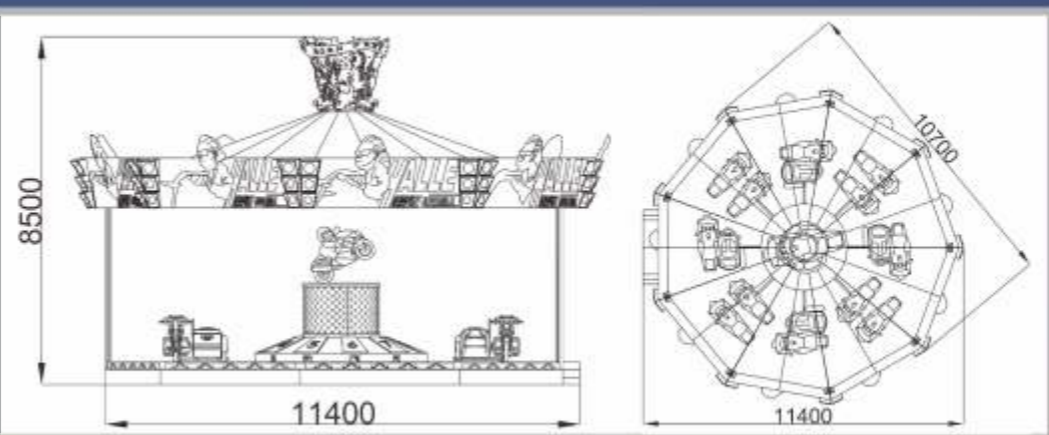



20seats armor carousel



34seats luxury carousel



46seats double deck carousel



20seats armor carousel



34seats luxury carousel

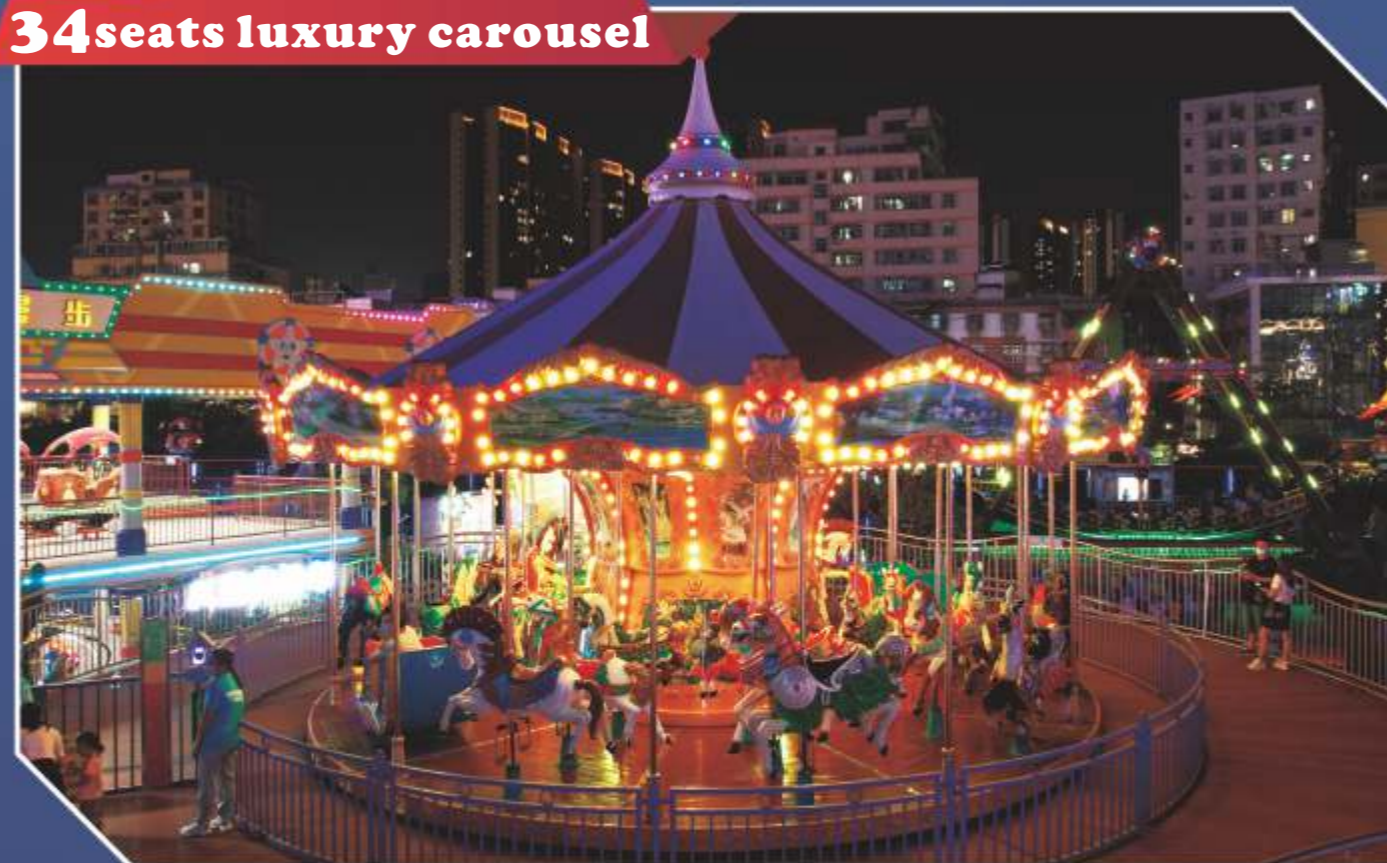



### 46seats double deck carousel

#### Specifications

Capacity: 46persons  
 Power: 9.5kW  
 Voltage: 380V/50Hz  
 Machine diameter: 12.4m  
 Area diameter: 13m  
 Height: 11m  
 Speed: 1.9m/s

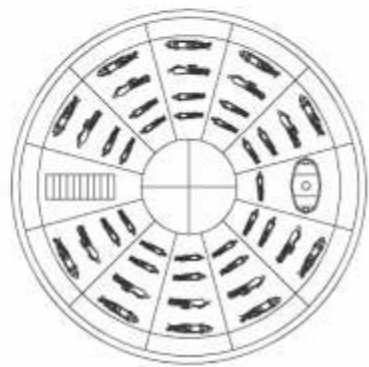
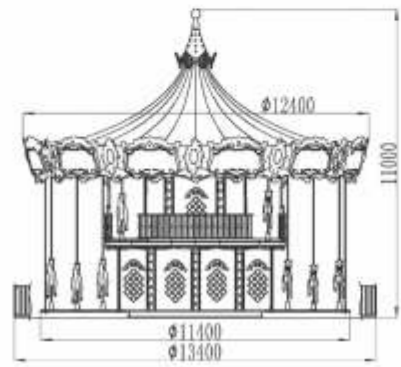

### 34seats luxury

#### Specifications

Capacity: 34persons  
 Power: 7.5kW  
 Voltage: 380V/50Hz  
 Machine diameter: 10.5m  
 Area diameter: 11.5m  
 Height: 7.9m  
 Speed: 1.9m/s

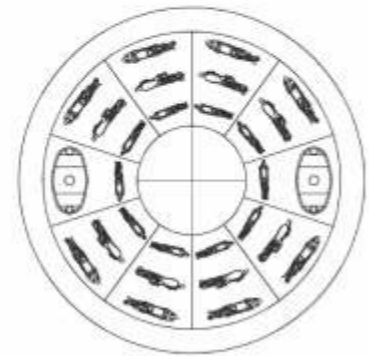
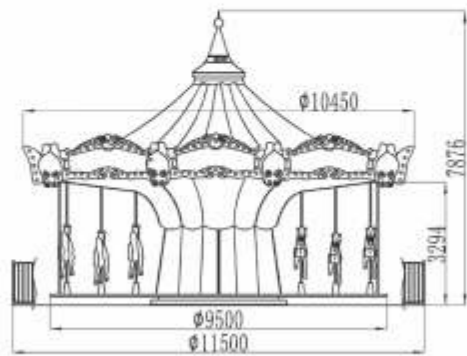

### 20seats armor

#### Specifications

Capacity: 20persons  
 Power: 3.5kW  
 Voltage: 380V/50Hz  
 Machine diameter: 7.4m  
 Area diameter: 8.5m  
 Height: 6.4m  
 Speed: 1.9m/s

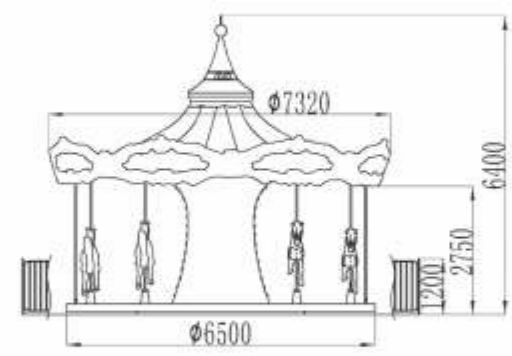



### Specifications

Capacity: 20persons  
 Cabins: 10pcs  
 Power: 14kW  
 Voltage: 380V/50Hz  
 Machine diameter: 11m  
 Area diameter: 13m  
 Speed: 1.9m/s

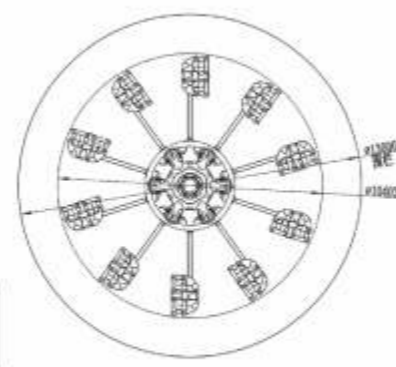
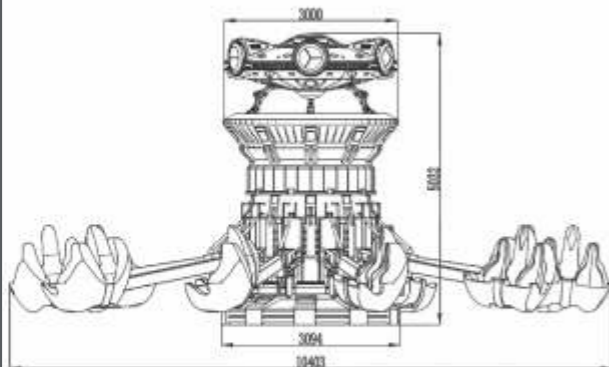



## Specifications

Capacity: 24 persons  
 Cabins: 6 pcs  
 Power: 11kW  
 Voltage: 380V/50Hz  
 Machine diameter: 7.5m  
 Area diameter: 9m  
 Speed: 1.9m/s

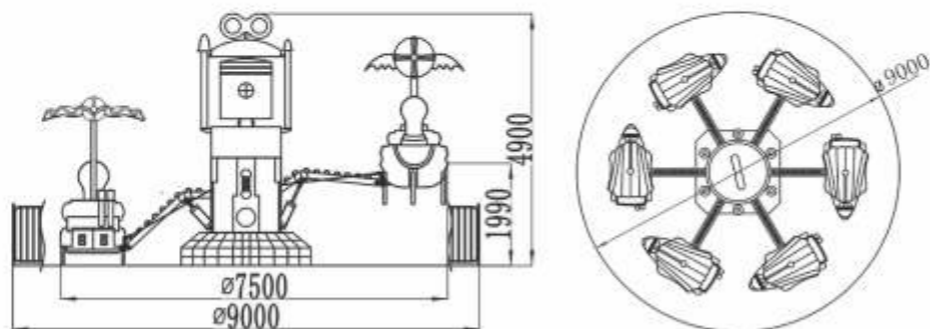



## Specifications

Capacity: 20persons  
 Power: 3.5kW  
 Voltage: 380V/50Hz  
 Machine diameter: 5.5m  
 Area diameter: 7m  
 Speed: 1.9m/s



## Specifications

Capacity: 20persons  
 Power: 3.5kW  
 Voltage: 380V/50Hz  
 Machine diameter: 8m  
 Area diameter: 8m  
 Speed: 1.9m/s

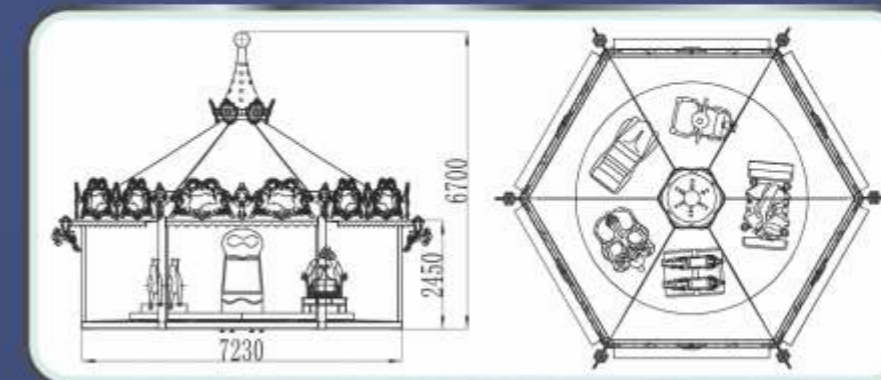
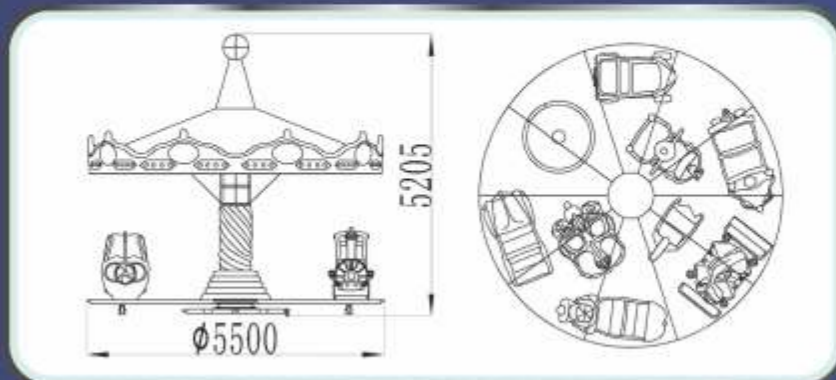

# Pirate Ship



## 40 Seats Specifications

Capacity: 40 persons  
 Product size: 16.3m\*8.2m  
 Area size: 22.8m\*9.2m  
 Swing angle: ±60°  
 Height: 13.7m  
 Power: 45kW  
 Swing radius: 11.4m

## 24 Seats Specifications

Capacity: 24 persons  
 Voltage: 380V/50kW  
 Machine size: 11m\*8.3m  
 Area size: 14m\*8.8m  
 Height: 9.5m  
 Power: 15kW  
 Running speed: 0.8pm



## Specifications

Capacity: 24 persons  
 Cabins: 6 pcs  
 Power: 11.5kW  
 Voltage: 380V/50Hz  
 Machine diameter: 6.5m  
 Area diameter: 8m  
 Speed: 1.95m/s

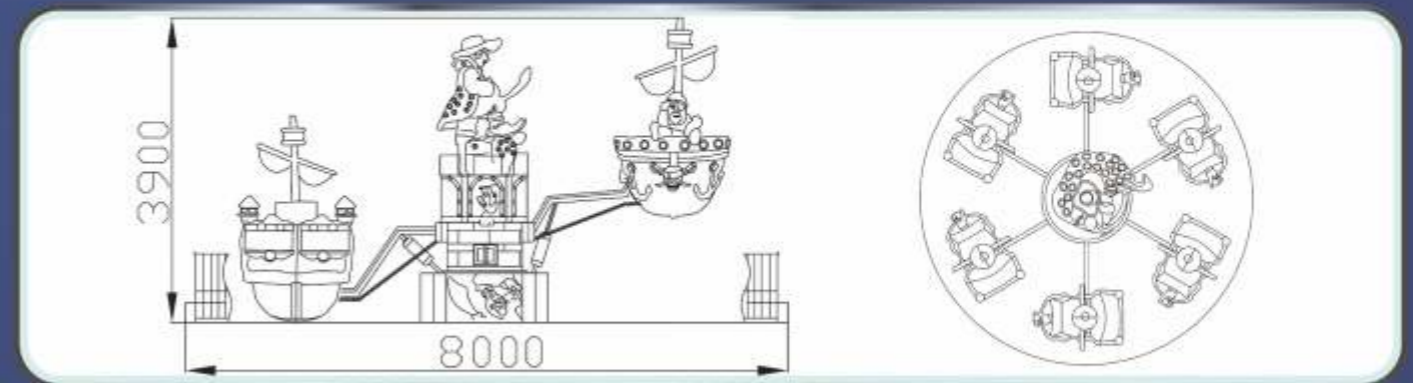



## Specifications

Capacity: 22 persons  
 Power: 12kW  
 Voltage: 380V/50kW  
 Machine diameter: 8m  
 Area diameter: 8m  
 Operation times and speed: adjustable



## Specifications

Capacity: 10 persons  
 Area: 5.5m x 2.5m  
 Height: 5m  
 Power: 3.5kW  
 Voltage: 380V/50Hz

## Specifications

Capacity: 72 persons  
 Power: 20kW  
 Voltage: 380V/50kW  
 Machine diameter: 18.3m x 15m  
 Operation hours and speed: adjustable





## Specifications

Capacity: 32 persons  
 Power: 19kW  
 Voltage: 380V/50Hz  
 Machine diameter: 12m  
 Area diameter: 18m  
 Height: 14m  
 Operation hours and speed: adjustable



## Specifications

Capacity: 24 persons  
 Power: 22kW  
 Voltage: 380V/50Hz  
 Rotation diameter: 6.5m  
 Area size: 20m\*10.6m  
 Track height: 4.57m  
 Running speed: 8.3m/s





## Vehicles



## Animals



**Specifications**  
 Capacity: 40 persons  
 Power: 5kW  
 Voltage: 380V/50kW  
 Area diameter: 13m  
 Height: 10.5m  
 Weight: 16t  
 Speed: 1.9m/s





### Specifications

Capacity: 24persons  
 Cabins: 12pcs  
 Power: 10.5kW  
 Voltage: 380V/50Hz  
 Machine diameter: 10.6m  
 Area diameter: 11m  
 Height: 5m  
 Speed: 1.88rpm



### Specifications

Capacity: 20persons  
 Cabins: 10pcs  
 Power: 5kW  
 Voltage: 380V/50Hz  
 Machine diameter: 8.7m  
 Area diameter: 8.7m  
 Height: 4.3m  
 Speed: 1.9m/s

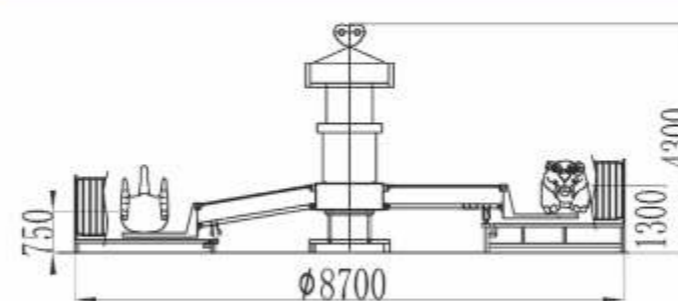
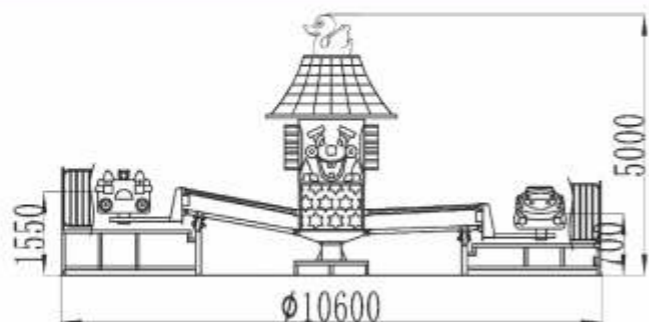

# Jumping Kangaroo



# Happy Conch



**Specifications**  
 Capacity: 16persons  
 Cabins: 8pcs  
 Power: 11.5kW  
 Voltage: 380V/50Hz  
 Machine diameter: 10m  
 Area diameter: 12m  
 Speed: 1.98m/s



**Specifications**  
 Capacity: 16persons  
 Power: 11.5kW  
 Voltage: 380V/50Hz  
 Machine diameter: 10m  
 Area diameter: 12m  
 Speed: 1.98m/s

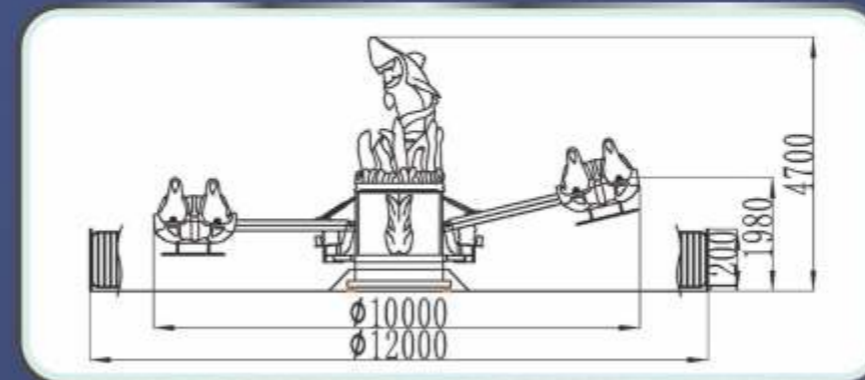
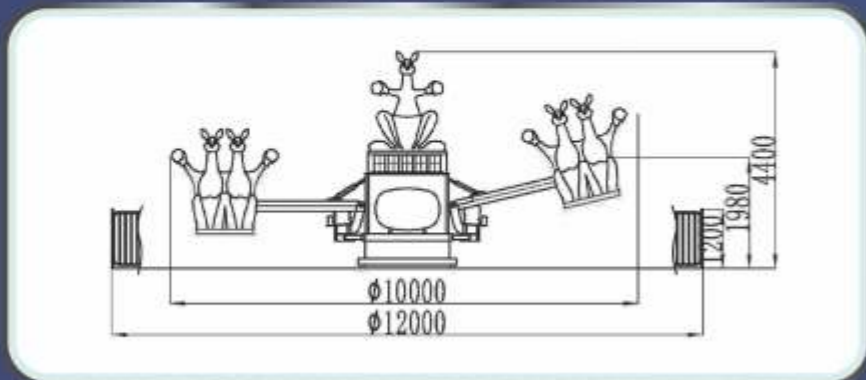



专利产品 仿冒必究

### Specifications

Capacity: 16persons  
 Power: 11.5kW  
 Voltage: 380V/50Hz  
 Machine diameter: 9m  
 Area diameter: 11m  
 Speed: 1.98m/s



### Specifications

Capacity: 32persons  
 Power: 10kW  
 Voltage: 380V/50Hz  
 Machine diameter: 9.6m  
 Area diameter: 11m  
 Speed: 1.98m/s

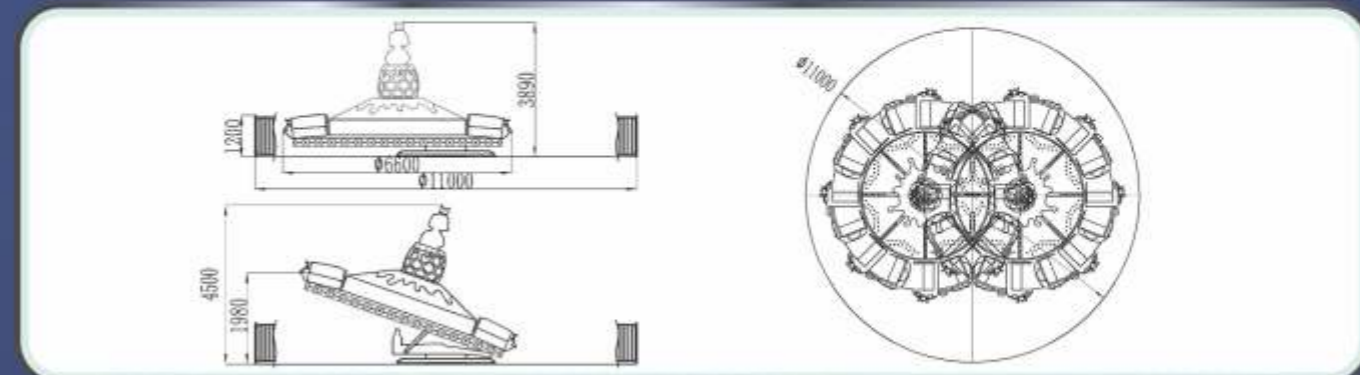
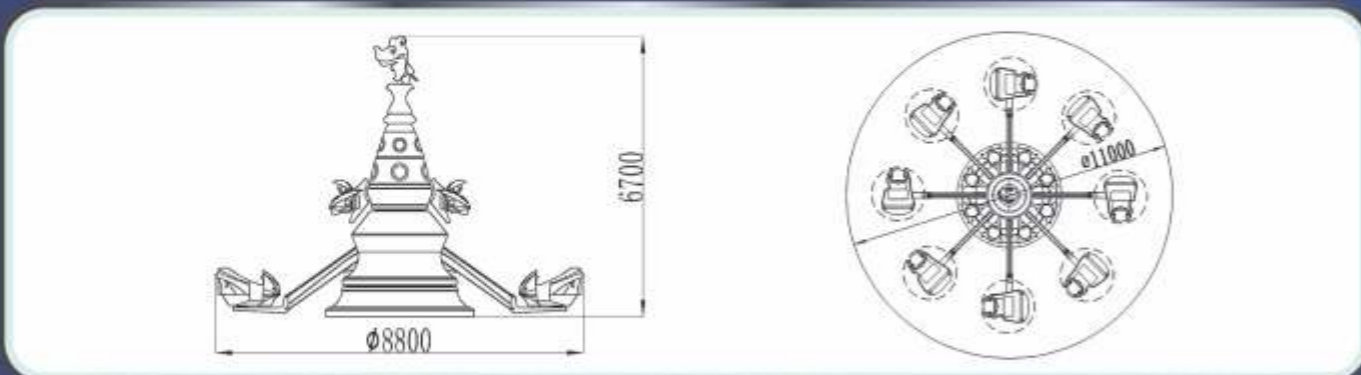



**Crazy Pirate**



**Pegasus Trip**



**Ocean Motorboat**



**Happy Pterosaur**



**Animal Kingdom**



**Pegasus Jumping**



**Flying Elephant**



**Sailing Boat**



**Specifications**

Capacity: 20persons  
 Power: 3.5kW  
 Voltage: 380V/50Hz  
 Machine diameter: 5.5m  
 Area diameter: 7m  
 Speed: 1.9m/s

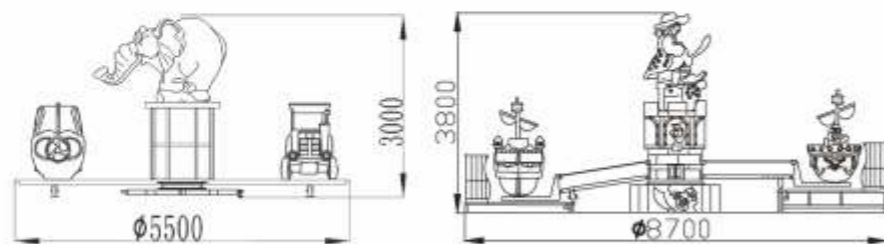

**Specifications**

Capacity: 24persons  
 Cabins: 6pcs  
 Power: 11kW  
 Voltage: 380V/50Hz  
 Machine diameter: 6m  
 Area diameter: 8m  
 Speed: 1.98m/s

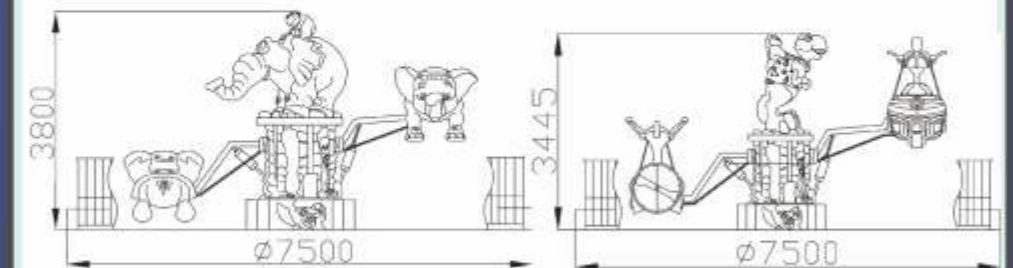

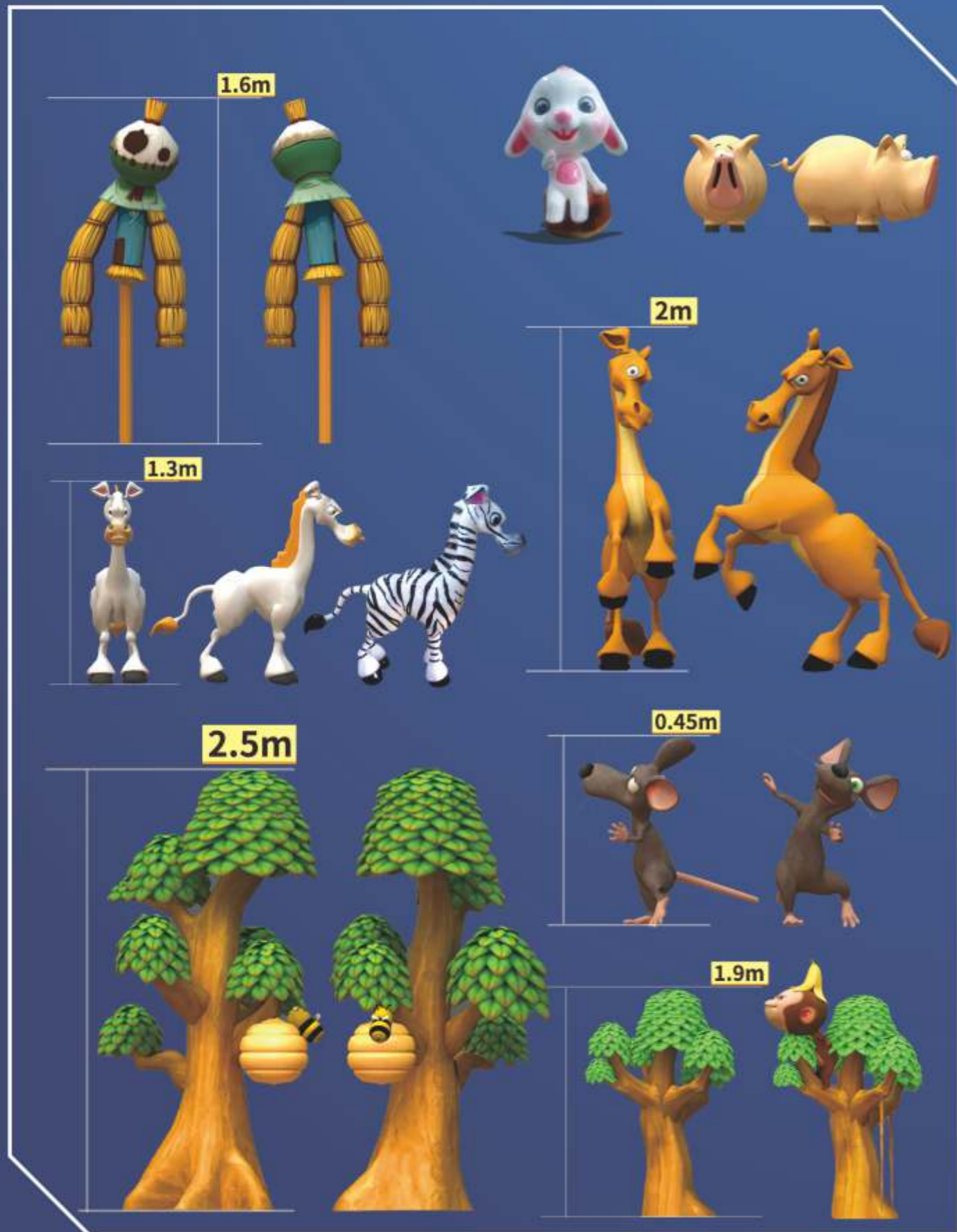

# Bounce Car



# Majic Jellyfish



## Specifications

Capacity : 24persons  
 Cabins : 6 pcs  
 Power : 8.5kW  
 Voltage : 380V/50Hz  
 Machine diameter:6m  
 Area diameter : 8m  
 Speed: 1.98m/s



## Specifications

Capacity : 32persons  
 Cabins : 8 pcs  
 Power : 9.5kW  
 Voltage : 380V/50Hz  
 Machine diameter:8m  
 Area diameter : 10m  
 Speed: 1.98m/s

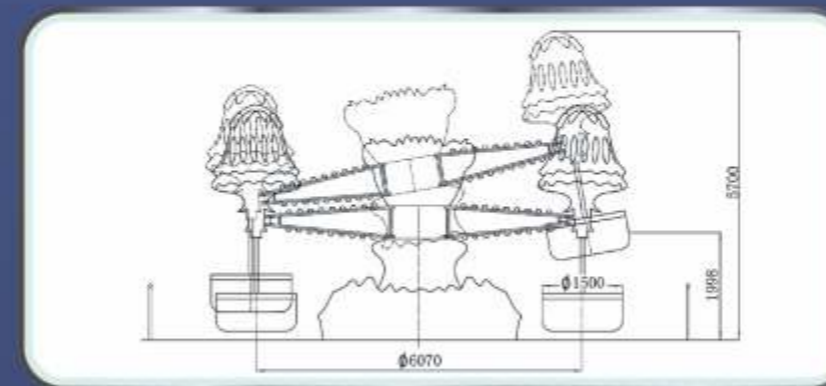
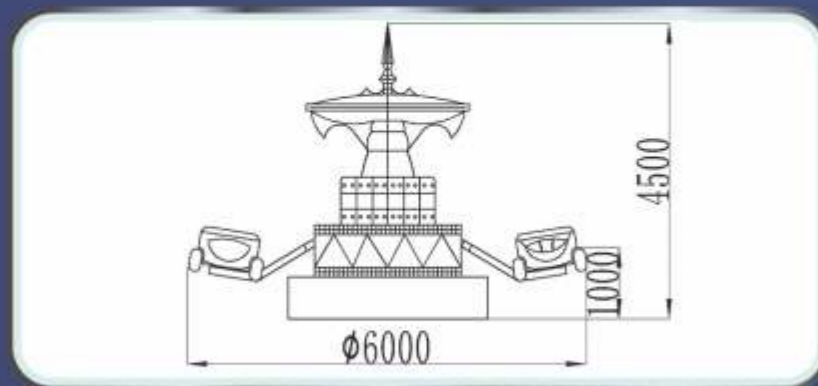



## Specifications

Capacity: 12 persons  
 Cabins: 4 pcs  
 Power: 3kW  
 Voltage: 380V/220V/50Hz  
 Track length: 45m  
 Area size: Be customized  
 Minimum turning radius: 2.8m  
 Speed: 1.9m/s (can adjust)

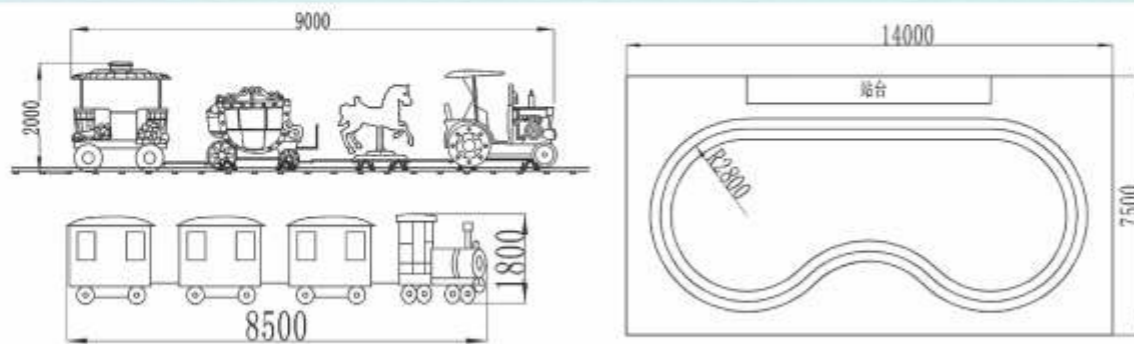

## Specifications

Capacity: 14 persons  
 Cabins: 4 pcs  
 Power: 2.5kW  
 Voltage: 380V/50Hz  
 Track length: 50m  
 Area size: Be customized  
 Minimum turning radius: 2.8m  
 Speed: 1.9m/s (can adjust)



